

T SERIES CATALOG

TOOLING

&

ACCESSORIES

Corporate Office

123 Oxmoor Road West • Birmingham, AL 35209
P.O. Box 59226 • Birmingham, AL 35259-9226
Telephone: 1/800/868-4100
Fax: (205) 945-4304

Mason-Dallas • 2080 McDaniel, Suite 125
Carrollton, TX 75006
Telephone: 1/800/756-2766 • Fax: (972) 247-7656

Mason-Kansas City • 1912 East 19th Street
Kansas City, MO 64127
Telephone: 1/800/925-0291 • Fax: (816) 241-7314

Mason-Knoxville • 1487 Amherst Road, Suite B
Knoxville, TN 37909
Telephone: 1/800/961-6266 • Fax: (865) 687-3841

Mason-Little Rock • 700 North Palm
North Little Rock, AR 72114
Telephone: 1/800/611-5162 • Fax: (501) 955-2147

Mason-Raleigh • 1601 Lake Wheeler Road
Raleigh, NC 27603
Telephone: 1/800/476-2593 • Fax: (919) 836-1944

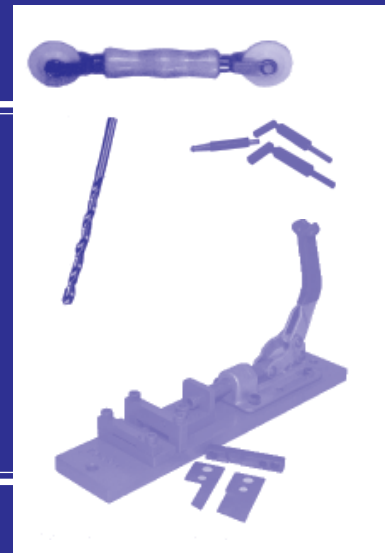

TOOLING & ACCESSORIES

SCREWDRIVER BITS

- T311 #2 Phillips Head - large
- T312 #1 Phillips Head - small



SCREW CHUCKS

- T313 5/16" Hex Head, Magnetic
- T314 1/4" Hex Head, Magnetic
- T315 3/8" Hex Head, Magnetic



DRIVE BIT

- T325 3" Long Square Head



DRIVE BIT

- T327 #30 Torx



DRILL BITS

- T357 Step-Down



Use to install C950B spring bolt latch.

SCREEN WIRE ROLLER

- T400 Double ended with one each .120" and .185" thick X 2" diameter nylon ball bearing mounted rollers.



TOOLING & ACCESSORIES

SCREEN WIRE ROLLER

T401 1/16" thick X 2 1/2" diameter, ball bearing mounted roller

Use to roll aluminum wire cloth into spline groove prior to spline application.

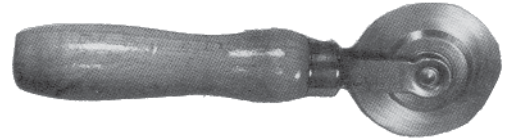

T402 1/8" thick X 2 1/2" diameter, ball bearing mounted

Use to roll aluminum wire cloth into .200" spline groove prior to spline application.

SCREEN WIRE ROLLER WITH FLANGE

T403 5/64" thick X 2 1/2" diameter, ball bearing mounted roller

Use to roll aluminum wire cloth into spline groove prior to spline application.



SCREEN WIRE ROLLER

T404 1/8" thick X 2" diameter, ball bearing mounted roller

Use to roll .160" diameter spline into spline groove.

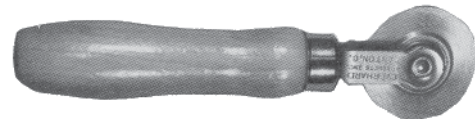

T405 7/64" thick X 2" diameter, ball bearing mounted roller

Use to roll .150" and .170" diameter spline into spline groove.

T406 3/16" thick X 2 1/2" diameter, ball bearing mounted roller

Use to roll .220" diameter spline into spline groove.

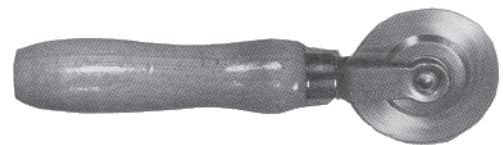

TOOLING & ACCESSORIES

BEVEL SPLINE ROLLER

T407 .062" thick at bevel X 2 1/4" diameter,
ball bearing mounted roller

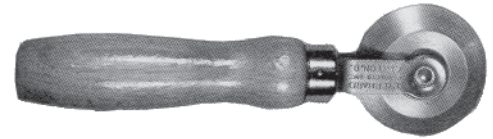

Use to roll any diameter vinyl spline into spline groove.

DOUBLE ENDED NYLON SPLINE ROLLER

T408



Use for fiberglass screening and E800A clear vinyl film installation.

NAIL SET TOOL

T412 Use to install friction hanger.

T413 Use to install C511A friction hanger.

T414 Use to install C512 friction hanger.

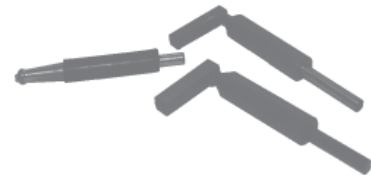

PUNCH

T431 Glass mold punch

Use to punch glass mold for E702A.

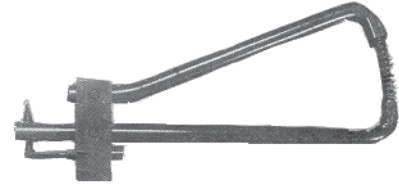

LANCING TOOL

T600 Screen frame lance

Use to lance screen frame for C901A and C902A slide latches, C002A retainer spring and C909A knife latch.

T599 Blade only for T600A lancing tool

Use to lance C002 retainer spring.

T608 Blade only for T600A lancing tool

Use to lance C909 knife latch.

T609 Blade only for T600A lancing tool

Use to lance C901 and C902 slide latches

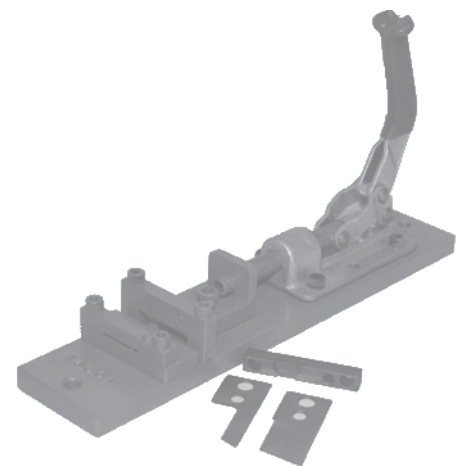

MASON CORPORATION
123 Oxmoor Road, West
Birmingham, AL 35209-6302

Telephone: 1/800/868-4100
Fax: 205/945-4304

TOOLING & ACCESSORIES

GLASS MOLD PUNCH

- T601 Bench Model
 T601A 0001 Replacement punch for T601
 T601A 0002 Replacement mandrel for T601
 T601A 0003 Replacement spring for T601

Use to punch glass mold for E702A wire corner clips.

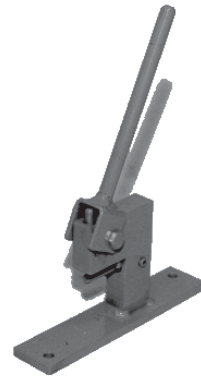

DIE

- T640 Bench Model
 T640A 0001 Roller punch
 T640A 0002 Latch punch

Use to punch and lance D100 sliding patio screen door main frame for latch and rollers.



DRILL JIGS AND JIGS

- T700 Drill Jig

*Use to locate roller adjustment screw in D100 patio screen door frame. **Note:** T367 - 9/64" diameter drill bit included with jig.*

- T740 Drill Jig

*Use to locate assembly screws in H121 porch enclosure frame for H130 porch enclosure frame. **Note:** Requires T361 - 11/64" diameter drill bit, not included.*

- T741 Jig

Use to position H126 clip when fabricating extruded porch enclosure.

- T760 Drill Jig

*Use to locate corner screw holes in E100 picture window frame. **Note:** Requires T361 11/64" diameter drill bit, not included.*



MASON CORPORATION
 123 Oxmoor Road, West
 Birmingham, AL 35209-6302

Telephone: 1/800/868-4100
 Fax: 205/945-4304

TOOLING & ACCESSORIES

TOOLING & ACCESSORIES FOR SCREEN AND INSULATING DOORS

T312 Phillips Head screwdriver bit

Use with D100 patio screen door and L141 Cushion-Lite® storm door.

T313 5/16" Magnetic screw chuck

Use with L141 Cushion-Lite® storm door.

T431 Hand-operated glass mold punch

Use with L141 Cushion-Lite® storm door.

T601 Bench model, Glass mold punch

Use with L141 Cushion-Lite® storm door.

T640 Bench model, Punch

Use to punch D100 latch and roller.

T700 Drill Jig

Use to locate holes in D100 door for adjustment screw.

